

BresicWhitney

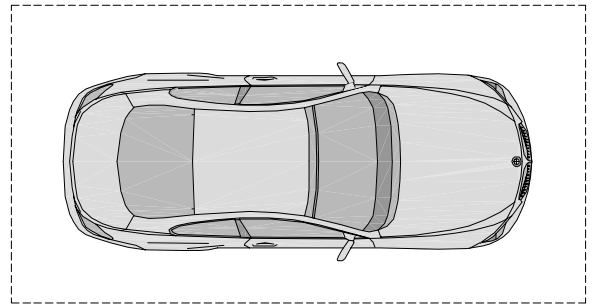

SECURITY CARSPACE

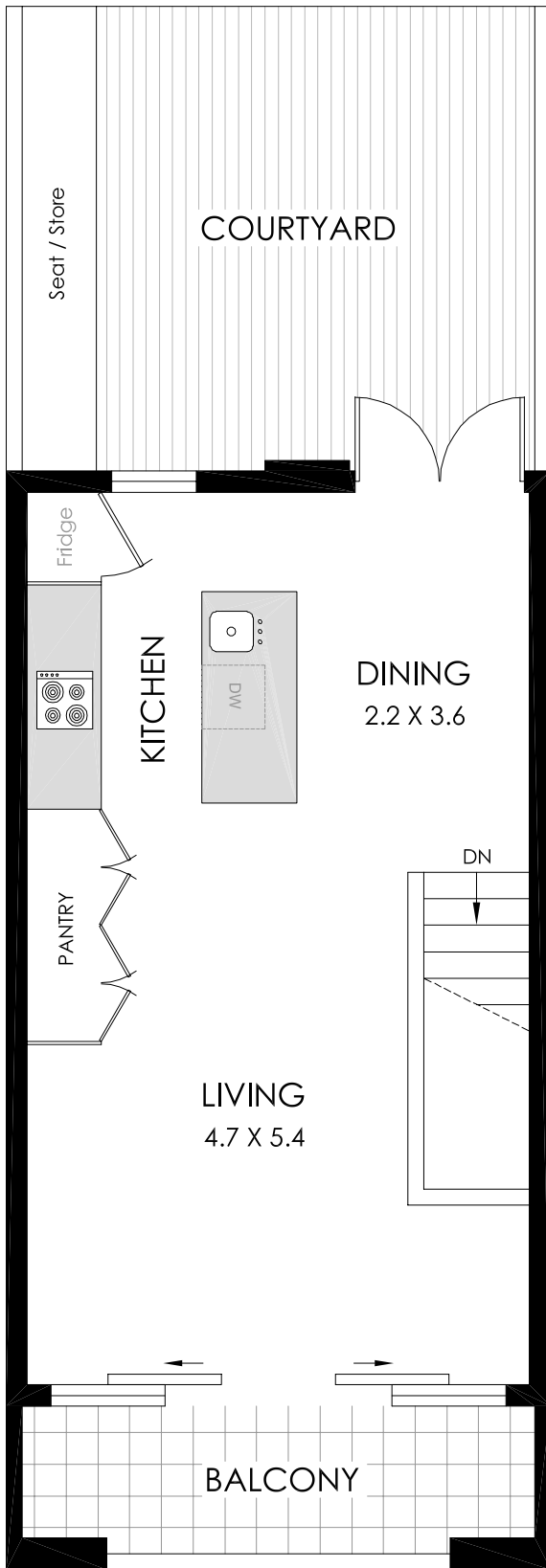

LEVEL 2

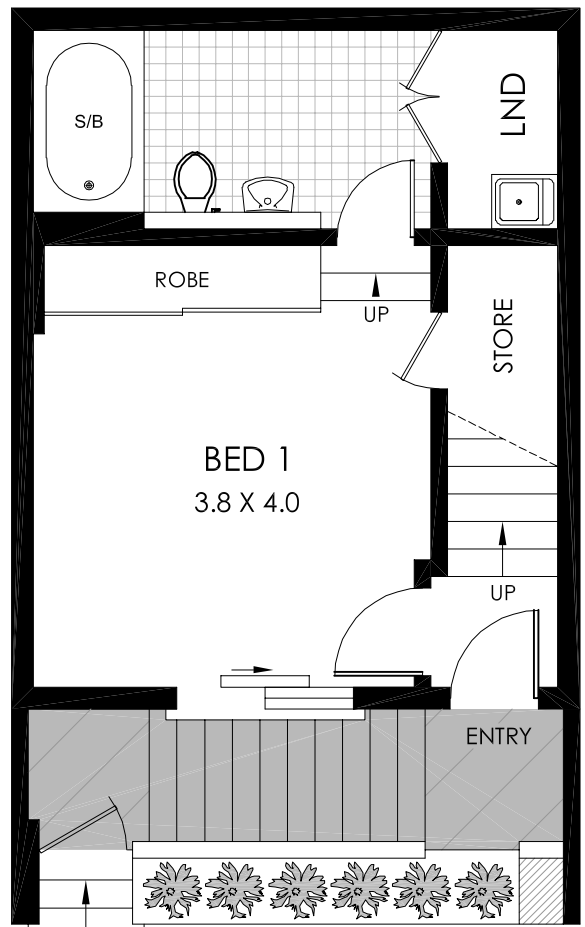

LEVEL 1



PLANS SHOWN ARE ONLY INDICATIVE OF LAYOUT. DIMENSIONS ARE APPROXIMATE

All information contained herein is gathered from sources we believe to be reliable, however we cannot guarantee its accuracy and interested persons should rely on their own enquiries. Dimensions are approximate.



F02/780 BOURKE STREET

Council Rates: \$683 pa
 Water Rates: \$577 pa
 Strata Levies: \$758 pq

EAST REDFERN

Internal: 67m²
 External: 29m²

Apartment Size: 96m²