

BresicWhitney

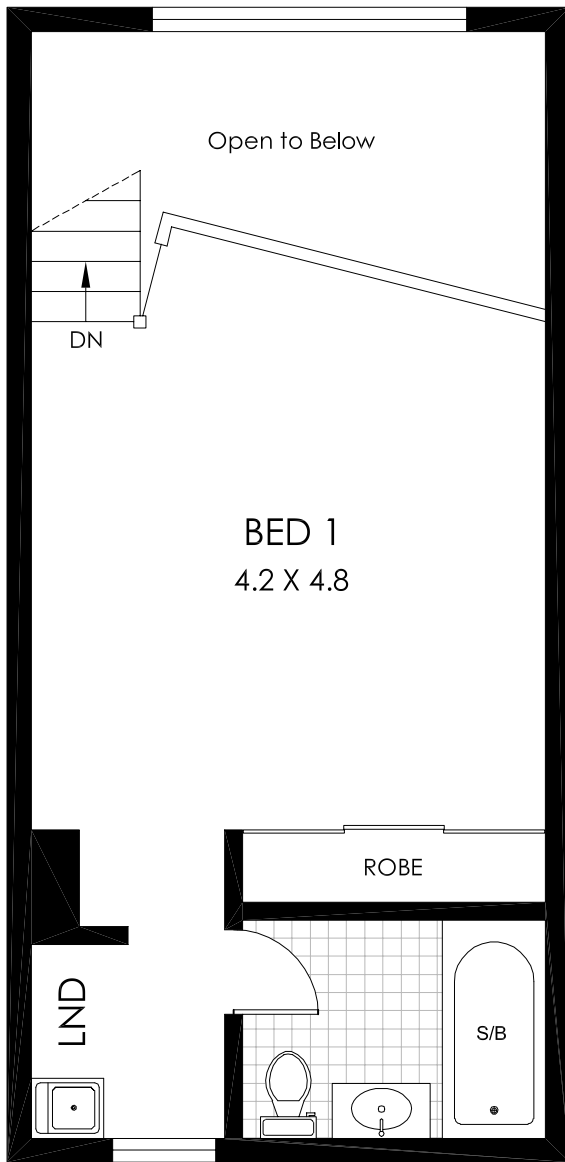

LEVEL 2

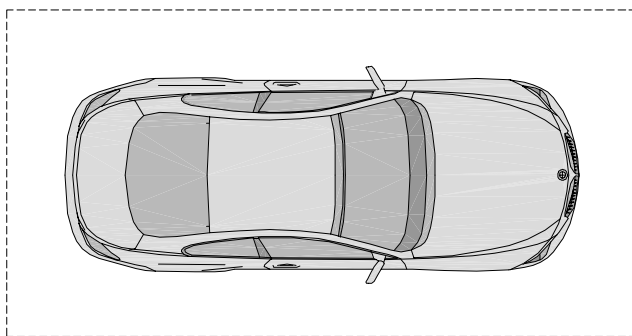

SECURITY CARSPACE

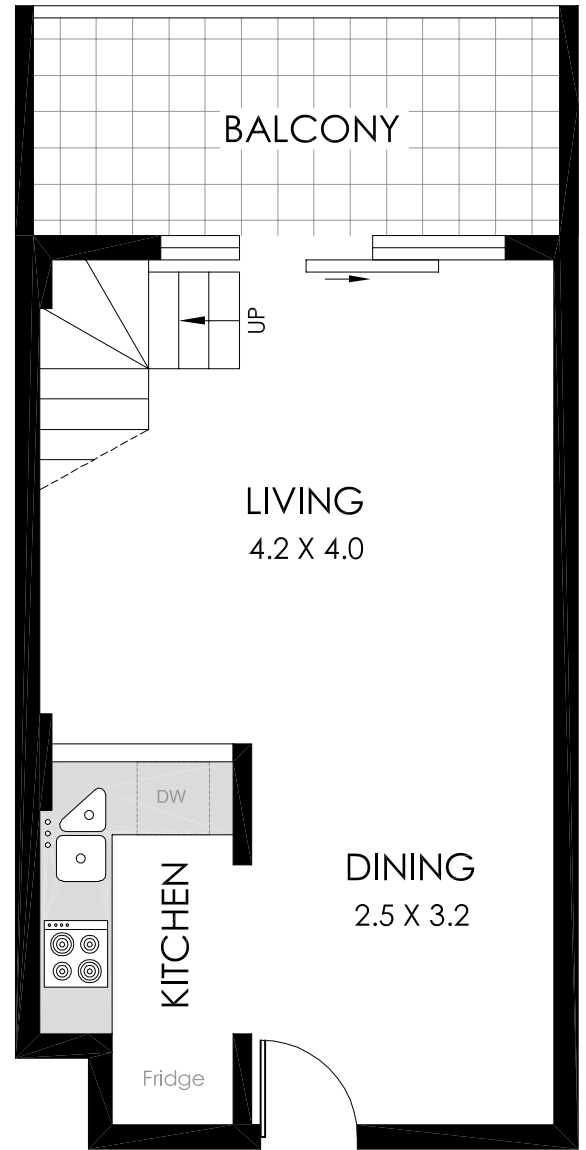

LEVEL 1

NOTE: STORAGE LOCKER

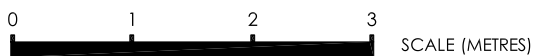

PLANS SHOWN ARE ONLY INDICATIVE OF LAYOUT. DIMENSIONS ARE APPROXIMATE

All information contained herein is gathered from sources we believe to be reliable, however we cannot guarantee its accuracy and interested persons should rely on their own enquiries. Dimensions are approximate.



409/1 POPLAR STREET

Council Rates: \$782 pa

Water Rates: \$557 pa

Strata Levies: \$834 pq

SURRY HILLS

Internal: 52m²

Balcony: 8m²

Apartment Size: 60m²